

## PT-29/PT-27/PT-28/BT-36/PT-31 TROLLEY

## INSTRUCCIONES DE MONTAJE

## ASSEMBLY INSTRUCTIONS

## INSTRUCTIONS D'ASSEMBLÉE

## Part list

Part no.	Drawing	Description	Qty.
A		Base Base Base	1
B		Protección anticaída Enclosure Pole Protección lateral	6
C1		Rueda de dirección fija con freno Fixed-direction wheel with brake Roue fixe avec frein	2
C2		Rueda giratoria con freno Swivel wheel with brake Roue pivotante avec frein	2
D		Tomillo Bolt Vis	16
E		Tuerca Nut Écrou	16
F		Arandela de acero Steel washer Rondelle d'acier	32
G		Llave inglesa Spanner Clé	2

Colocar B X 6 piezas en el alojamiento cuando se almacene el carro.

Put B X 6 pcs in the catcher when store the trolley.

Mettez B X 6 pièces dans la poule de preneur quand emmagasine le chariot.

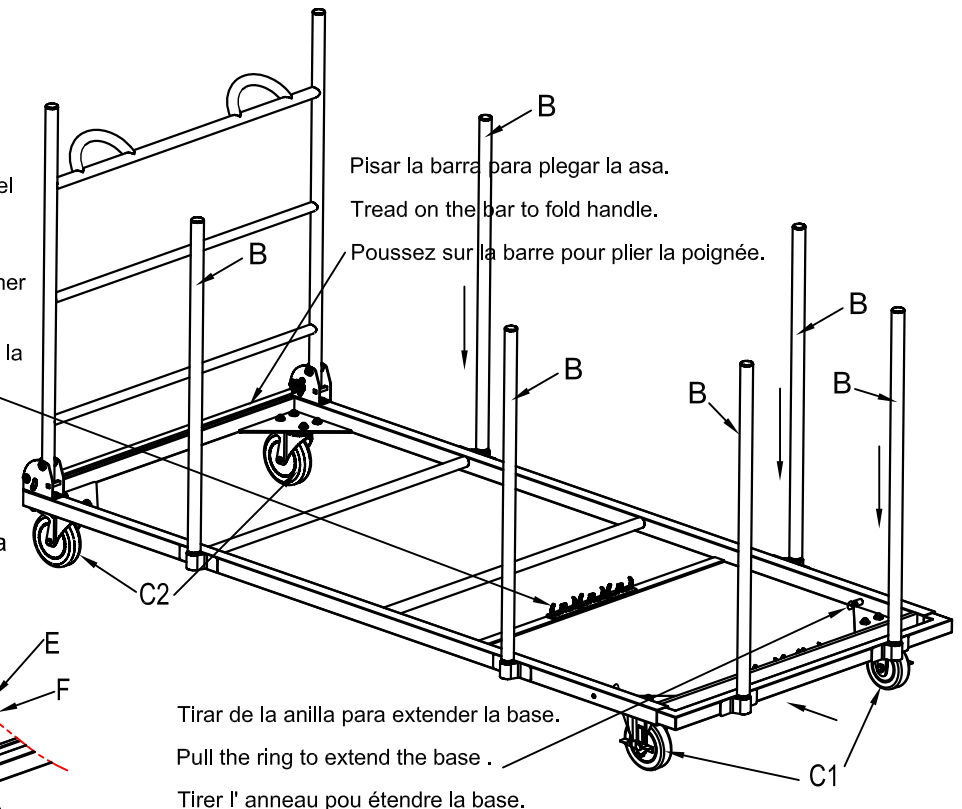
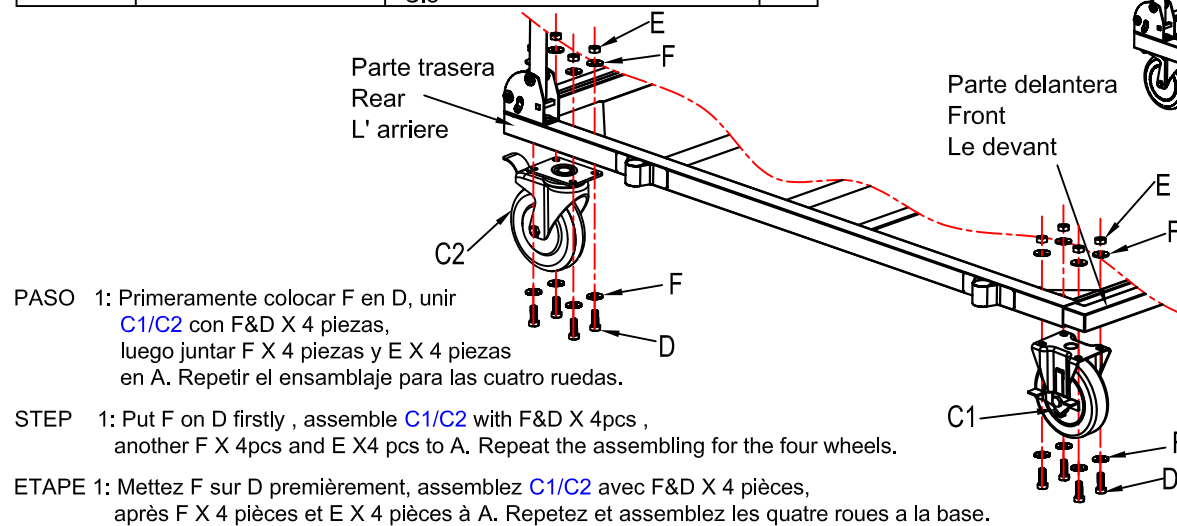

PASO 2: Insertar B X 6 piezas a la base.

STEP 2: Insert B X 6 pcs to base.

ETAPE 2: Mettez B X 6 pièces à la base.