







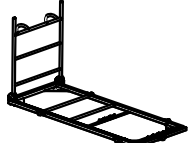

## BT-06BK/BT-08B/BT-05BK TROLLEY

## INSTRUCCIONES DE MONTAJE

## ASSEMBLY INSTRUCTIONS

## INSTRUCTIONS D'ASSEMBLÉE

## Part list

| Part no. | Drawing  | Description   | Qty. |
|----------|--|---|------|
| A        |   | Base<br>Base<br>Base  | 1    |
| B        |   | Protección anticaída<br>Enclosure Pole<br>Protección lateral                                  | 5    |
| C1       |   | Rueda de dirección fija con freno<br>Fixed-direction wheel with brake<br>Roue fixe avec frein | 2    |
| C2       |   | Rueda giratoria con freno<br>Swivel wheel with brake<br>Roue pivotante avec frein             | 2    |
| D        |   | Tomillo<br>Bolt<br>Vis  | 16   |
| E        |   | Tuerca<br>Nut<br>Écrou  | 16   |
| F        |   | Arandela de acero<br>Steel washer<br>Rondelle d'acier   | 32   |
| G        |  | Llave inglesa<br>Spanner<br>Clé   | 2    |

# ZOWN

CONTRACTDESIGNFACTORY

**MAXCHIEF EUROPE S.L.**

EU-Spain B-64775638

C/ Roger de Flor, 93-95

08013 Barcelona, SPAIN

[www.zowncontract.com](http://www.zowncontract.com)[www.maxchiefeurope.com](http://www.maxchiefeurope.com)

Tel. + 34 93 453 6600

Fax. + 34 93 451 8894

Colocar B X 5 piezas en el alojamiento cuando se almacene el carro.

Put B X 5 pcs in the catcher when store the trolley.

Mettre B X 5 pièces dans la poule de preneur quand emmagasine le chariot.

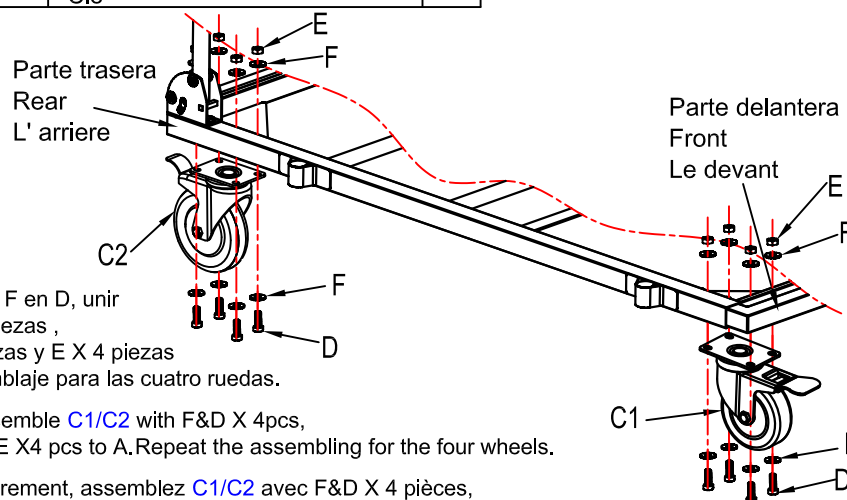
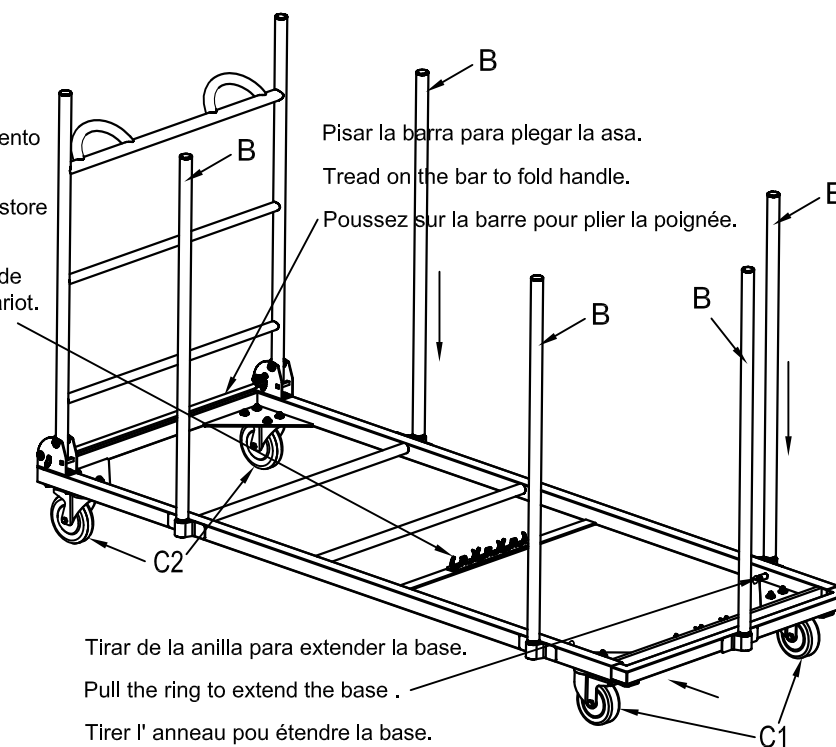

PASO 1: Primeramente colocar F en D, unir C1/C2 con F&D X 4 piezas, luego juntar F X 4 piezas y E X 4 piezas en A. Repetir el ensamblaje para las cuatro ruedas.

STEP 1: Put F on D firstly, assemble C1/C2 with F&D X 4 pcs, another F X 4 pcs and E X 4 pcs to A. Repeat the assembling for the four wheels.

ETAPE 1: Mettez F sur D premièrement, assemblez C1/C2 avec F&D X 4 pièces, après F X 4 pièces et E X 4 pièces à A. Repétez et assemblez les quatre roues à la base.

PASO 2: Insertar B X 5 piezas a la base.

STEP 2: Insert B X 5 pcs to base.

ETAPE 2: Mettez B X 5 pièces à la base.